

## Background

- The first stage of acceleration for the Large Hadron Collider (LHC) is Linac4 (L4) [1]
- H<sup>-</sup> ions are generated by the gun and pass through the Low-Energy Beam Transport (LEBT) to the Radio Frequency Quadrupole (RFQ) [2]
- An endoscopy of the L4 RFQ showed signs of vane damage and breakdowns [2]
- It was believed that the damage was due to H<sup>-</sup> losses, irradiating the Copper OFE (Cu-OFE) creating blisters that caused breakdowns
- To gain more knowledge of this effect, tests were carried out in a pre-existing DC setup after sample irradiation at the H<sup>-</sup> source test stand [3]

## Pulsed DC Large Electrode System (LES) Study

- The LES consists of two high-precision-machined electrodes placed 20 μm to 100 μm apart in vacuum with a voltage of up to 10 kV, pulse lengths from 1 μs to 1ms, and frequencies up to 6 kHz [4]
- Operated to study conditioning and vacuum breakdown phenomena
- The instrumentation detects breakdowns using voltage, current, pressure, and light, giving the location of each breakdown during operation
- Different materials have been tested, with three results of interest discussed below
- Two pairs of each material were tested of which one pair included an irradiated cathode [5], with the same dose as the RFQ would receive over 10 days, estimated to be 1.2x10<sup>19</sup> H<sup>-</sup> p/cm<sup>2</sup>
- Visually distinct areas after irradiation include the beam spot, beam pipe outlet halo, and areas with no change to the electrode [6]
- To replicate the conditions in the RFQ, a pulse length of 100 μs, and a repetition rate of 200 Hz were used, and the electric field was first ramped to 35 MV/m before increasing to find the limit [2]
- The summary plot below shows the materials tested, and the maximum and final stable fields achieved

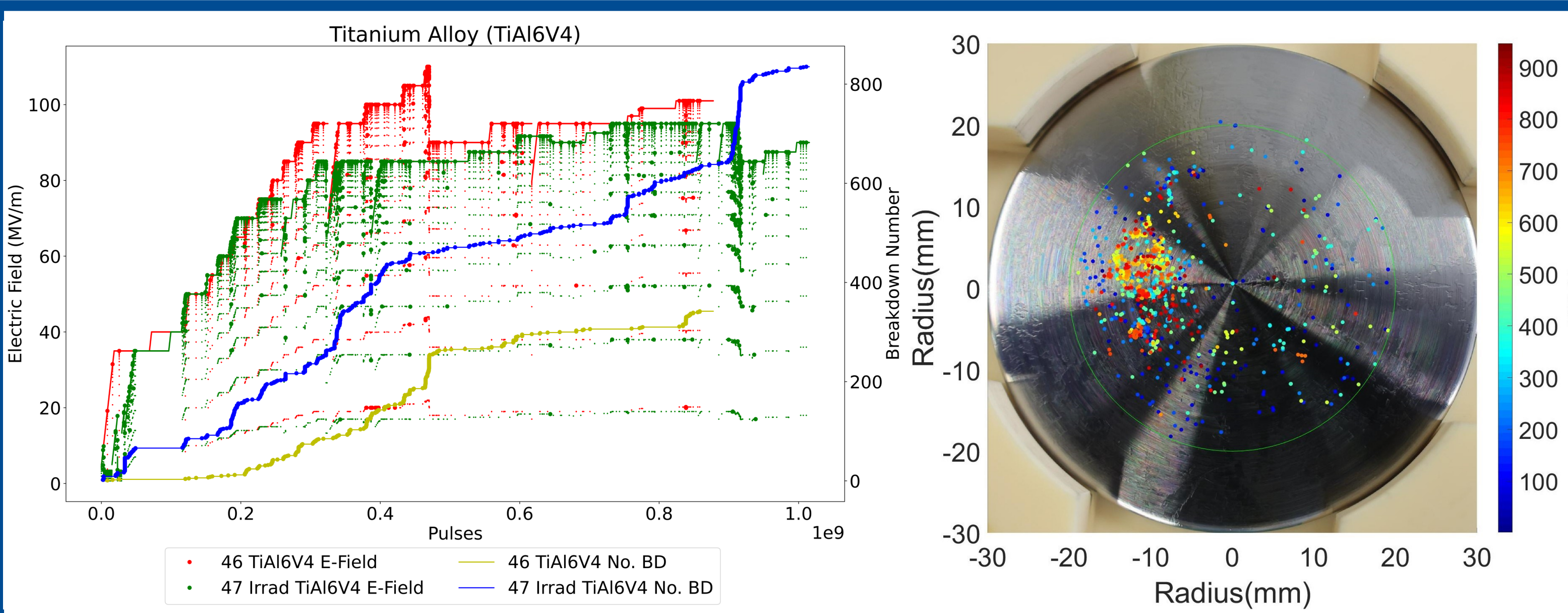
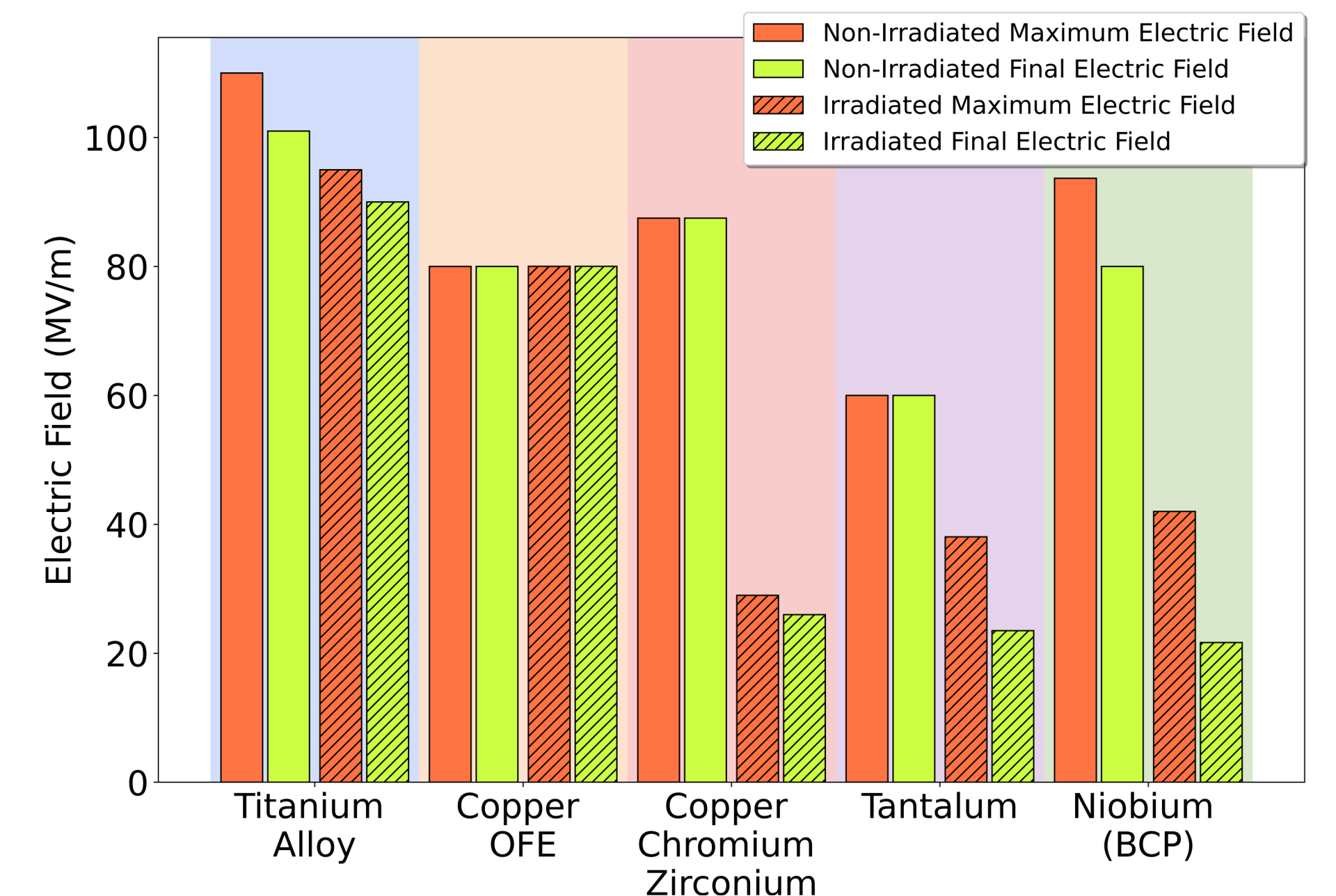
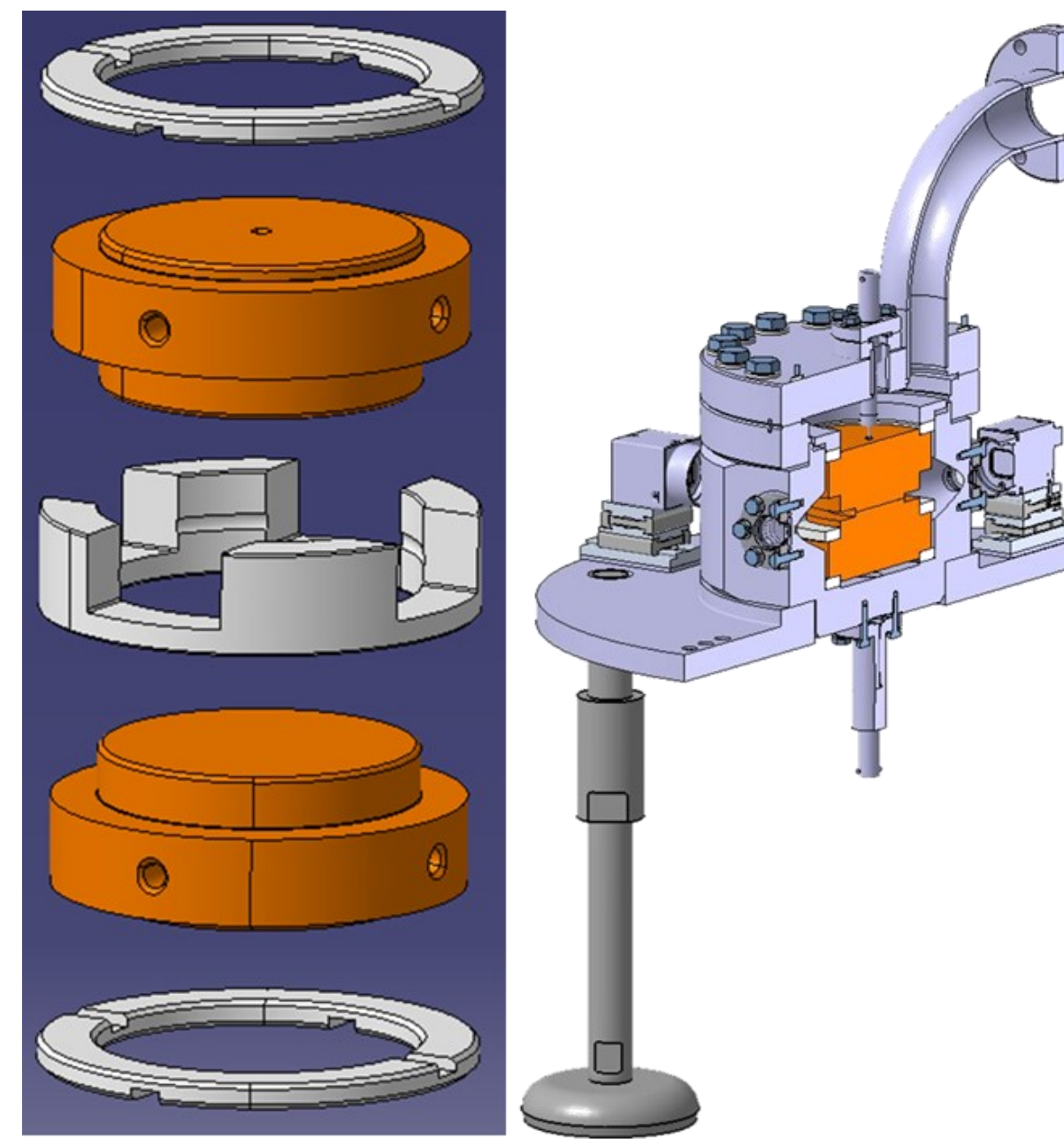
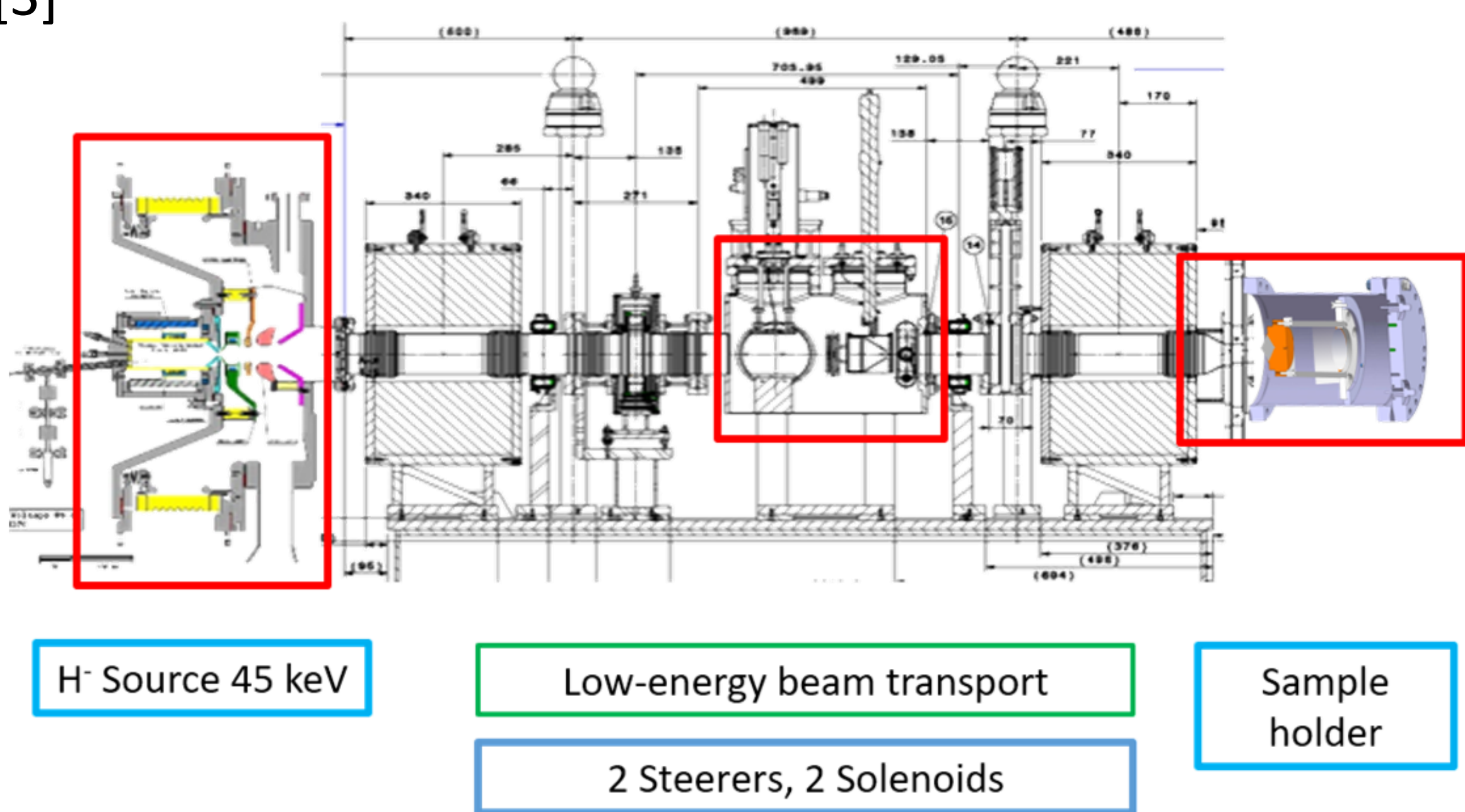

### Titanium Alloy (TiAl6V4)

- Chosen due to its resistance to blistering, this material showed no physical defects from irradiation [6]
- Discolouration was seen, with a visible difference between the beam spot and halo
- Reached the highest stable field both irradiated and non-irradiated
- The non-irradiated electrodes achieved a higher field
- Both pairs exhibited a temporal cluster of breakdowns that required a reduction of the field to reduce the risk of further clusters
- Breakdown locations had a higher concentration on one side and within the halo area, suggesting it is an effect of the halo and possible non-parallelism of the electrodes

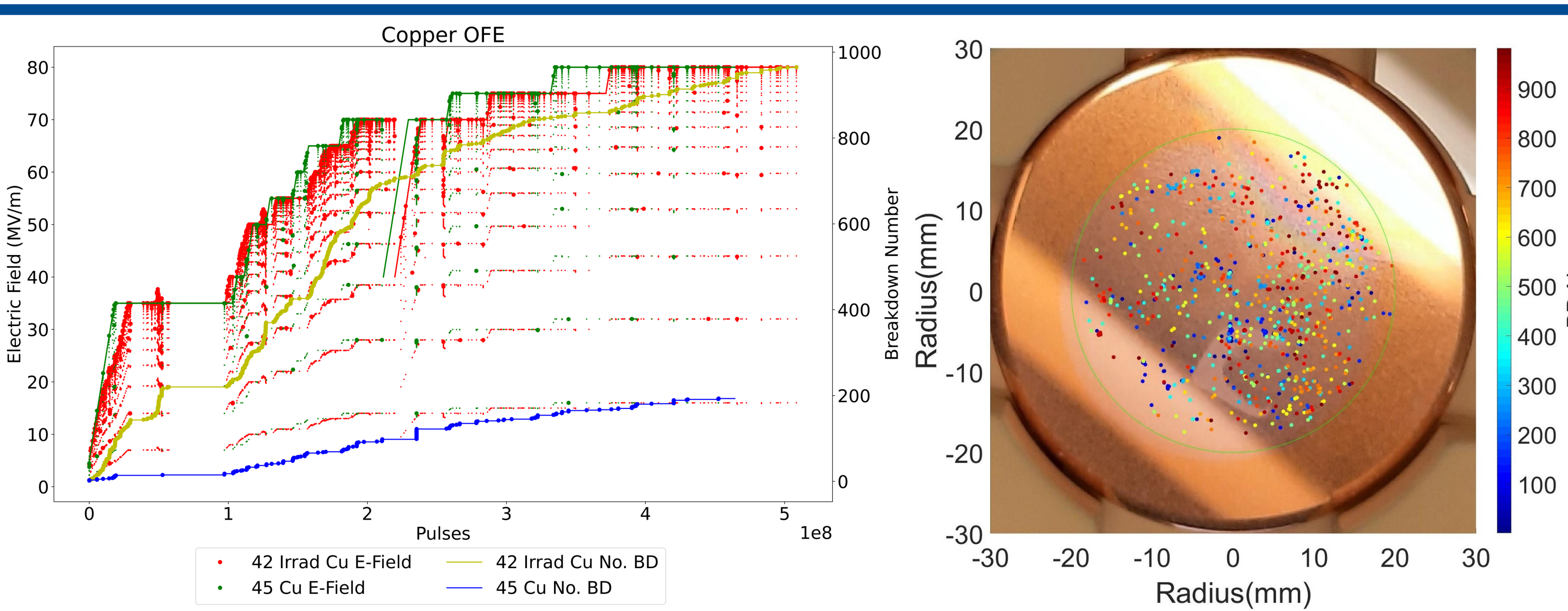

### Oxygen-Free Electronic Copper (Cu-OFE)

- Blisters were observed in the beam spot area of the electrode and discolouration was observed in the halo [6]
- Achieved the same stable E-field for irradiated and non-irradiated
- The irradiated pair experienced a larger number of breakdowns at the start that decreased with conditioning suggesting that it conditioned away issues caused by irradiation
- Temporal clusters of breakdowns occurred during some attempts to increase the field of the irradiated pair, but after pulsing for longer at the previous stable field an increase in field was possible
- Spatial clusters on the irradiated electrode occurred in different areas of the halo and not all of the beam spot [6]

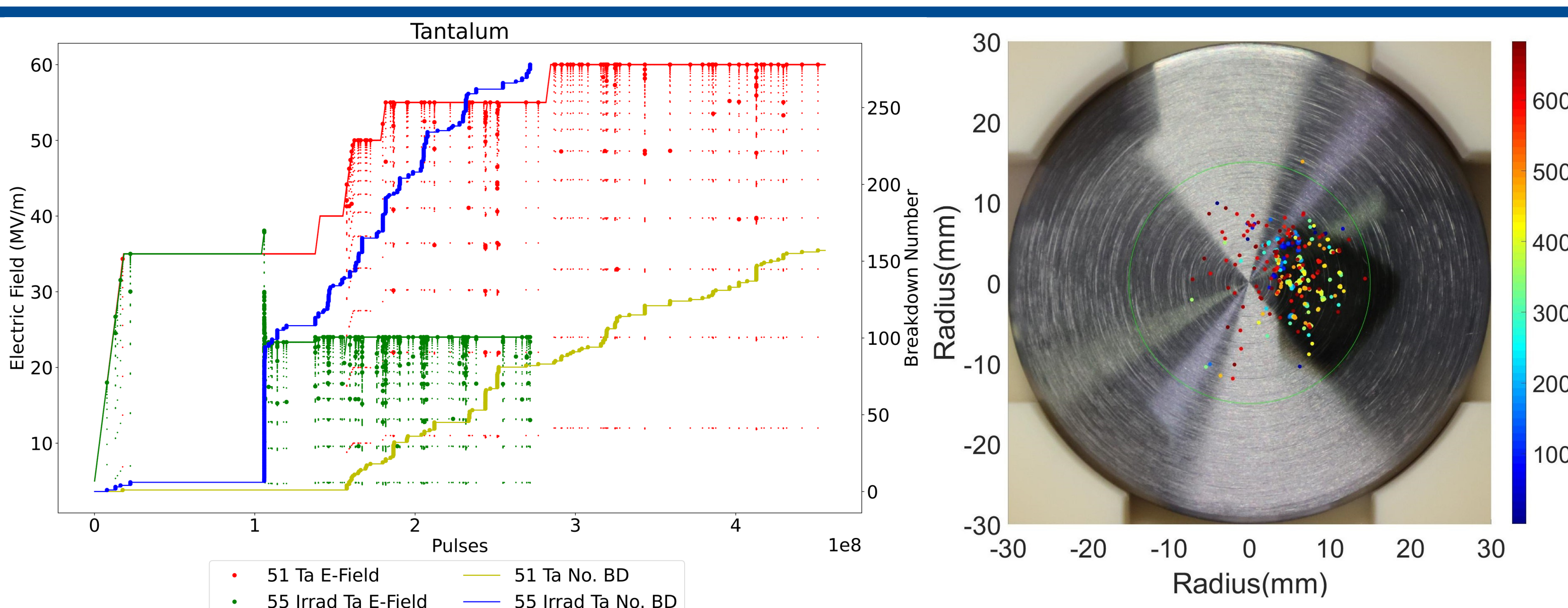

### Tantalum (Ta)

- No physical defects from irradiation. Discoloration was seen, with a visible difference between the beam spot and halo (Half circle collimator used) [6]
- The irradiated pair had a large temporal cluster of BDs at 38MV/m reducing the field and was unable to recover; Niobium (Nb) performed in a similar way
- Both non-irradiated Ta and Nb pairs did not experience large temporal clusters, suggesting the cluster was an effect of irradiation, indicating both materials are unsuitable choices for an RFQ
- Breakdowns for Ta were largely clustered spatially on the beam spot suggesting something happened causing more breakdowns

## Summary

- The best choices of material for an RFQ, based on these results are TiAl6V4 and Cu-OFE
- Both TiAl6V4 pairs reached the highest stable field. However, they displayed unpredictable instabilities causing a decrease in the obtainable field
- Both Copper pairs achieved the same field with an initial increase in the number of breakdowns that conditioned away defects of the irradiated pair
- Nb and Ta both had significant reactions to irradiation, causing a large and unpredictable cluster in breakdowns that could not be recovered from
- Breakdown locations for TiAl6V4, Cu-OFE, were distributed over the halo area and did not show preference to the beam spot for irradiated electrodes
- For the non-irradiated electrodes breakdowns were distributed over the whole high field area, with fewer and smaller spatial clusters
- The experimental conditions differ from those of the RFQ as irradiation was done before testing rather than constant irradiation throughout
- Re-irradiating or constant irradiation may affect the performance and/or the ability to condition to the same field